



- **Minimum Depth Indicator - Less Than 2.5" (60mm) of Space Required Behind the Panel**
- **Stackable Mounting Bracket Included for Easy Installation**
- **LCD: 4-1/2 Digit, 0.5" (12.7mm) High Display with Optional Negative Image, Bright Red Backlighting**
- **LED: 4-1/2 Digit, 0.4" (10.2mm) High Display**
- **Limited Range Display Scaling**
- **Standard Screw Terminals for Easy Installation**
- **Six Current Ranges: 200µA, 2mA, 20mA, 200mA, 2A, 5A**
- **LCD: 85-250VAC or 9-32VDC Power Supply**
- **LED: 85-250VAC Power Supply**



LCD



LED

Simpson's Mini-Max Voltage Indicators provide high quality, accuracy and reliability in a compact, 60mm deep case.

LCD (Liquid Crystal Display) Units offer a 4-1/2 digit, 0.5" (12.7mm) LCD display with an optional bright red, negative image, backlight.

LED (Light Emitting Diode) Units offer a 4-1/2 digit, 0.4" (10.2mm) display.

All units feature user-selectable decimal point, auto zero and limited scaling capabilities.

A unique mounting bracket is provided to allow for vertical or horizontal stacking of multiple indicators. All Mini-Max units feature a 3/64 DIN, high-impact plastic case. The LCD units have a clear viewing window and the LED units have a red viewing window.

Installation and Panel Cutout

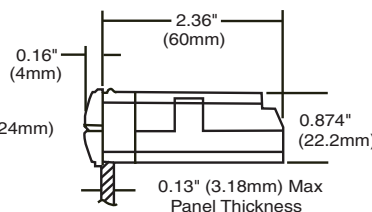
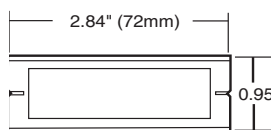
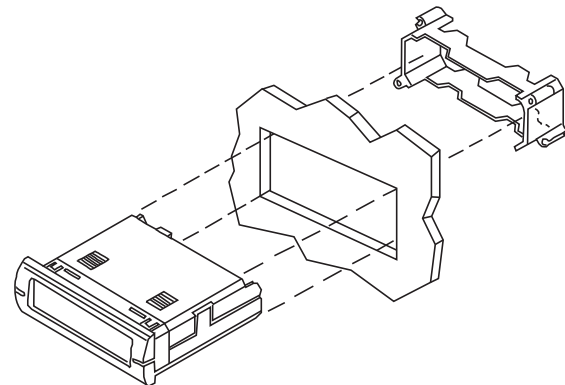
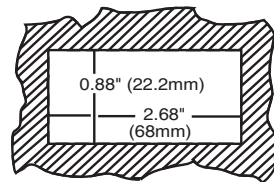
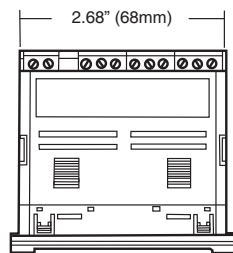

Mounting Requirements

Insert the Mini-Max through the panel, and then slide the mounting bracket onto the Mini-Max. The mounting bracket allows Mini-Max units to be stacked side-to-side or top-to-bottom and to maintain the DIN standard panel arrangements in 24mm by 72mm multiples. Panel cutout instructions for stacking multiple units are provided under "stacking features."

Specifications

DISPLAY

Type: 7-segment LCD or LED
Height: LCD 0.5" (12.7mm)
 LED 0.4" (10.2mm)

Decimal point: 4-position selectable

Overrange indication:

LCD Most significant digit = "1"
 LED Blinking display

LCD Backlighting: Optional negative image, red backlight

Polarity: Auto with "-" indication, "+" implied

POWER REQUIREMENTS

AC Volt: 85-250VAC @40-440Hz
DC Volt: 9-32VDC (LCD version only)

Power Consumption: (Non Fused)

85-250VAC: LCD 4.0VA (2.4W) max
 LED 3.6VA (2.16W) max
 9-32VDC: LCD 3W max

Isolation: 250Vrms

NOISE REJECTION

CMRR: 86dB typical

ACCURACY @ 25°C

LCD $\pm(0.5\%$ of reading + 50 count)
 (50 Hz - 2 KHz)
 LED $\pm(0.5\%$ of reading + 10 count)
 (50 Hz - 5 KHz)

ENVIRONMENTAL

Operating Temperature: 0 to 55°C
Storage Temperature: -10 to 60°C
Relative Humidity: 0 to 85% non condensing @ 40°C
Temperature Coefficient:
 (0.2% of reading \pm 0.5 digits) / °C
Warmup time: Less than 20 minutes

ANALOG TO DIGITAL CONVERSION

Technique: Integrating dual slope
Rate: 3 samples/second-typical

MECHANICAL

Bezel: 0.95" x 2.84" (24mm x 72mm)
Depth: 2.36" (60mm)
Panel cutout: 0.88" x 2.68"
 (22.2mm x 68mm)
Weight: LCD 3.5oz (99.2g)
 LED 2.6oz (74g)

Case Material:

94-0,UL-rated glass-filled thermoplastic

ACA TRMS		LCD	LCD	LED	LED
Range	Resolution	Voltage	Max Input	Voltage	Max Input
	M245	Drop	Unfused	Drop	Unfused
200uA	10nA	200mVdc	10mA	200mVdc	6mA
2mA	100nA	200mVdc	40mA	200mVdc	20mA
20mA	1uA	200mVdc	100mA	200mVdc	60mA
200mA	10uA	200mVdc	400mA	200mVdc	300mA
2A	100uA	200mVdc	3A	200mVdc	2.6A
5A	1mA	50mVdc	6A	100mVdc	6A

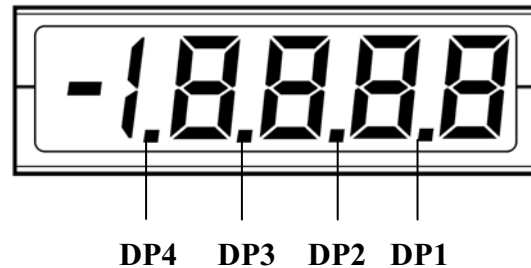

Connections

LCD VERSIONS

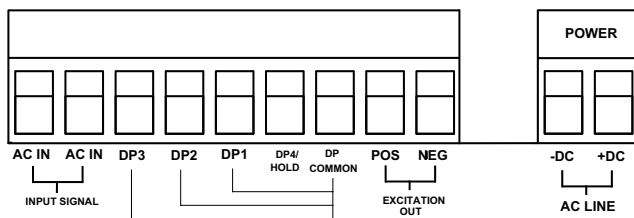

LED VERSIONS

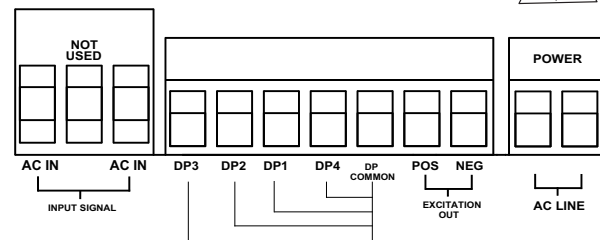

WARNING: These instruments are designed for maximum safety to the operator when mounted in a panel according to instructions. They are not to be used unmounted or for exploratory measurements in unknown circuits.

- Input Signal:** Connect the AC signal to be monitored to the **AC IN** input terminals.
- Input Power:** For AC power, connect the AC POWER LINE to the **AC LINE** inputs. For optional DC power, connect the DC Supply to the DC inputs. Observe polarity.
- Decimal Point:** To select a decimal point, connect the appropriate DP input pin (DP1 - DP4) to the DP COMMON output. Unused DP inputs may remain unconnected (open).
- LCD Hold Option:** Connect the DP COMMON output to the **HOLD** input. If this feature is not required, the HOLD pin may remain unconnected. Hold is optional on LCD versions only, replaces DP4 and is available from our modification center.
- LCD Backlight Option:** Negative image, bright red backlighting is available for the LCD versions only. This illumination allows the unit to be read in low light areas. Backlighting power is supplied by the Mini-Max, so no additional external power is required.
- Excitation Option:** Excitation is available at the **EXCITATION OUT** Positive (**POS**) and Negative (**NEG**) terminals for powering external transmitters or transducers. This source is isolated from the measurement input as well as the input power circuits. The voltages available are 12Vdc or 24Vdc with a maximum load current of 25mA. This feature eliminates the need to mount an external DC power source for transducers or sensors used in your application.

LCD Display Scaling

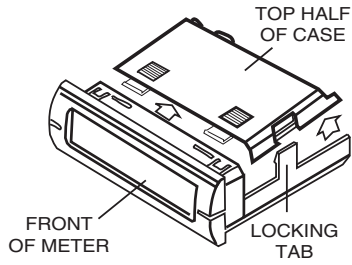

Using a screwdriver or thumbnail, spread the tabs on each side of the case to unlock the top half. Lift the rear of the top half and slide it away from the front of the meter.

Scale Adjustment:

Mini-Max indicators have limited range coarse and fine adjustments for display scaling. There are no optional connections required for these to function. The meter can be scaled down to 1/2 the value of the input, or scaled up to 1 times the value of the input, or a maximum reading of 1.9999, whichever is lower.

LCD VERSIONS

Scale Adjustment:

The "Coarse" adjustment R12 will allow a limited range of scaling values. The "Fine" adjustment R9 allows for an adjustment range of approximately 1% of the "Coarse" adjustment. Apply the full scale input to the meter. Adjust R12 to be within 1% of the desired result. Then use R9 to obtain the final desired result.

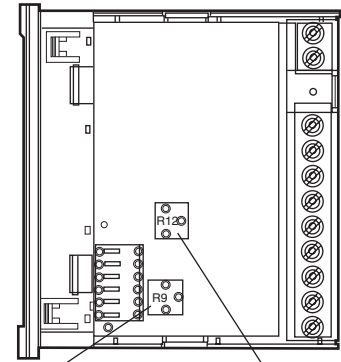

SCALE ADJ.
FINE

SCALE ADJ.
COARSE

Note: Any physical damage to the meter during adjustment will void the warranty.

LED VERSIONS

Scale Adjustment:

The "Coarse" adjustment RV1 will allow a limited range of scaling values. The "Fine" adjustment RV2 allows for an adjustment range of approximately 1% of the "Coarse" adjustment. Apply the full scale input to the meter. Adjust RV1 to be within 1% of the desired result. Then use RV2 to obtain the final desired result.

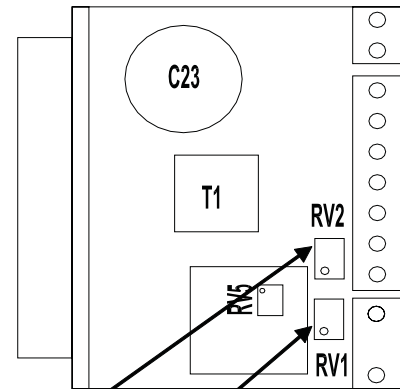

SCALE ADJ.
FINE

SCALE ADJ.
COARSE

Note: Any physical damage to the meter during adjustment will void the warranty.

Stacking Features

The mounting brackets, included with every Mini-Max, can be connected together. Multiple units can be mounted in a single opening, allowing perfect alignment.

To punch one hole for multiple units, be sure to adjust the standard panel cutout dimensions as shown here; otherwise the meters will not fit properly in the hole.

Mounting multiple units is quick and easy. Install the first meter (bottom unit first if stacking vertically). Position the next mounting bracket snugly against the first one, and slide the second meter into place. Repeat for remaining units.

Vertical

Standard cutout

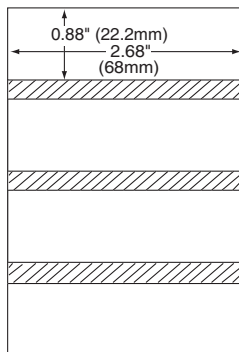

0.071" (1.8mm)
Add to standard
when stacking

Vertical

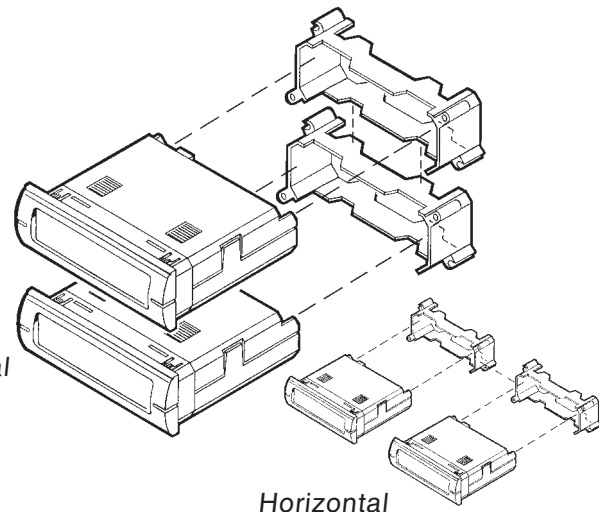

Horizontal

Horizontal

Standard cutout



0.16" (4.0mm)
Add to standard
when stacking

Application Example

A company needs to monitor the power supply voltage (120VAC), load current (50 amps), and frequency (60Hz) of an AC motor.

Voltage: A Mini-Max 200 Volt AC meter is installed in parallel with the power supply.

Current: A Mini-Max 5 Amp AC meter is attached to a 50:5 amp Donut Current Transformer. The meter must be scaled to display 50.00 when 5 amps are applied. R9 and R12 (LCD), RV1 and RV2 (LED) are adjusted until the correct value is displayed. The meter is connected to the donut, and the AC line is fed through the donut.

Frequency: A Mini-Max 200Hz Frequency meter is installed in parallel with the power supply. The wiring for the volt meter can be split to to the frequency meter as long as the voltage will not exceed 750 volts AC. [Note: Frequency Meter is available in model M235 LCD only.]

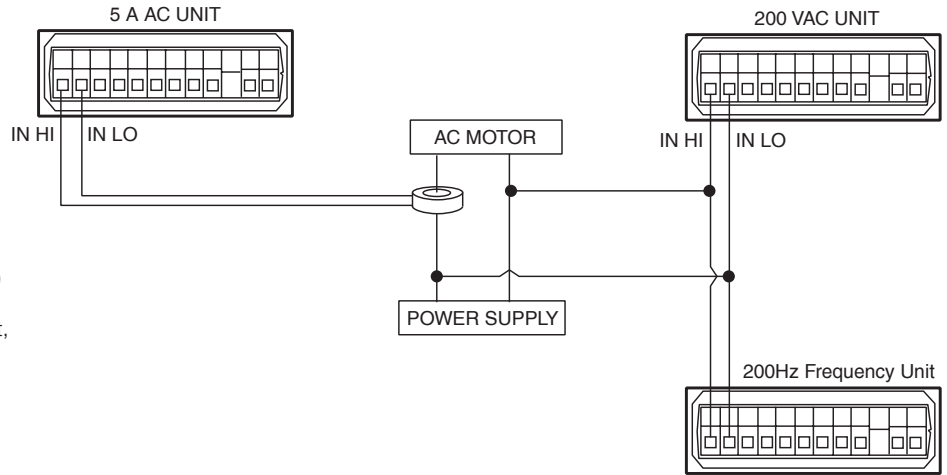

Ordering Information

Your Mini-Max Current Indicator can be configured by making an entry for each box

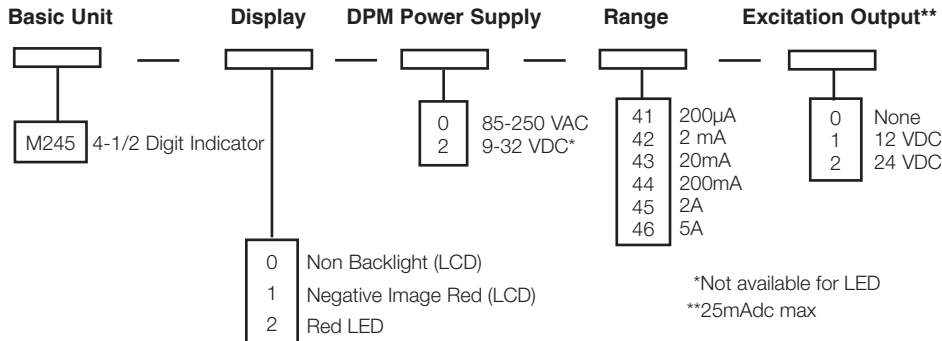

Note: LCD display hold feature is configured at the factory and must be specified at time of order.

Note: Special scaling is available from the factory at the time of ordering

Safety Symbols



The WARNING sign denotes a hazard. It calls attention to a procedure, practice, or the like, which if not correctly performed or adhered to, could result in personal injury.

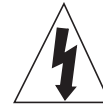

The CAUTION sign denotes a hazard. It calls attention to an operating procedure, practice, or the like, which if not correctly adhered to, could result in damage to or destruction of part or all of the instrument.

Accessories

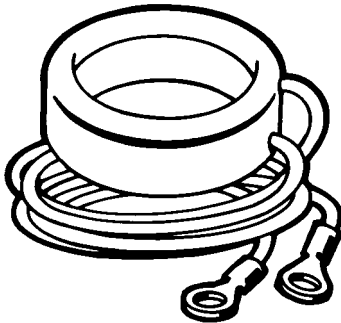

Donut Current Transformers enable the Mini-Max to monitor AC current up to 5000 amps. The Donut (also known as a "Toroid") is placed around one of the legs of the device being monitored and emits up to a 5 amp signal. The Mini-Max can be scaled to accurately display the current being monitored. Each Donut comes with 2' long secondary leads.

Ordering Information

Range/Amps		Cat. No.
Pri	Sec	
50	5	01293
75	5	01306
100	5	01297
150	5	01298
200	5	01299
250	5	01313
300	5	01300
400	5	01305
500	5	01301
600	5	02303
750	5	02459
1000	5	02304